

CITYLINE EXPRESS

4 Page Newspaper Offset Press



MANUGRAPH
Technology in Print

Meeting Multicolor Printing requirements with amazing variety

CITYLINE EXPRESS puts its major focus on multicolour printing with a wide range of modules. The very concept of CITYLINE EXPRESS is the ability to provide a combination of different print modules to meet a variety of production requirements. CITYLINE EXPRESS is a single width, single circumference machine from the Manugraph stable, running at a maximum speed of 35,000 revolutions per hour. All controls are PLC based for ease of operation. CITYLINE EXPRESS facilitates a wide gamut of printing applications such as newspapers, supplements, books, magazines etc. Short web path ensures excellent print quality and reduced waste.

CITYLINE EXPRESS Features at a glance

- Printing speed of 35,000 revolutions per hour.
- Reel stand or Flying splicer in Inline, 90°, Stacked or Integrated version.
- Pneumatics for impression, inking and dampening form roller, ink take up roller on-off.
- 7 roller inking system with 2 form rollers of different diameters & 1 bigger oscillating roller.
- 4 Roller contact less Brush Dampening System.
- Motorized Lateral & Circumferential Register System for 6 Print couples (2 print couple is having fixed position and kept as a base print couple).
- Web severer at entry of the Tower & bigger diameter Greater roller at exit of the Tower.
- Jaw Folder - 1:2:2 or 2:2:2.
- PLC base Electrical System.
- 2 Touch panels per Tower for Print function.
- Shear Pin for safety.
- Bustle wheels to minimise fanout.
- Easy coupling & decoupling arrangement in main drive.

Criteria for selection of your CITYLINE EXPRESS Print Unit Modules

Printing units are available in Mono unit & H unit with vertical web lead. A Tower is made up of 2 H units stacked one over the other. For back to back 4 colour printing, tower module is most ideal. Its short web path ensures perfect register at maximum speed. Tower units to meet 4/1, 4/2 requirements are also available. With 2 Reelstands / Splicers, a tower can handle two webs. For more pagination with single colour printing, Mono units coupled with Integrated Reelstand is quite effective. Reelstand / Splicer units are flexible in placement and can be kept in line, at right angles, stacked or integrated to suit the space available. Different print modules can be configured to suit pagination and colour requirements. Tower with Integrated Autopaster is a solution for presses having less floor space and more pagination. CITYLINE EXPRESS Print Modules can also be added on to your existing presslines easily.

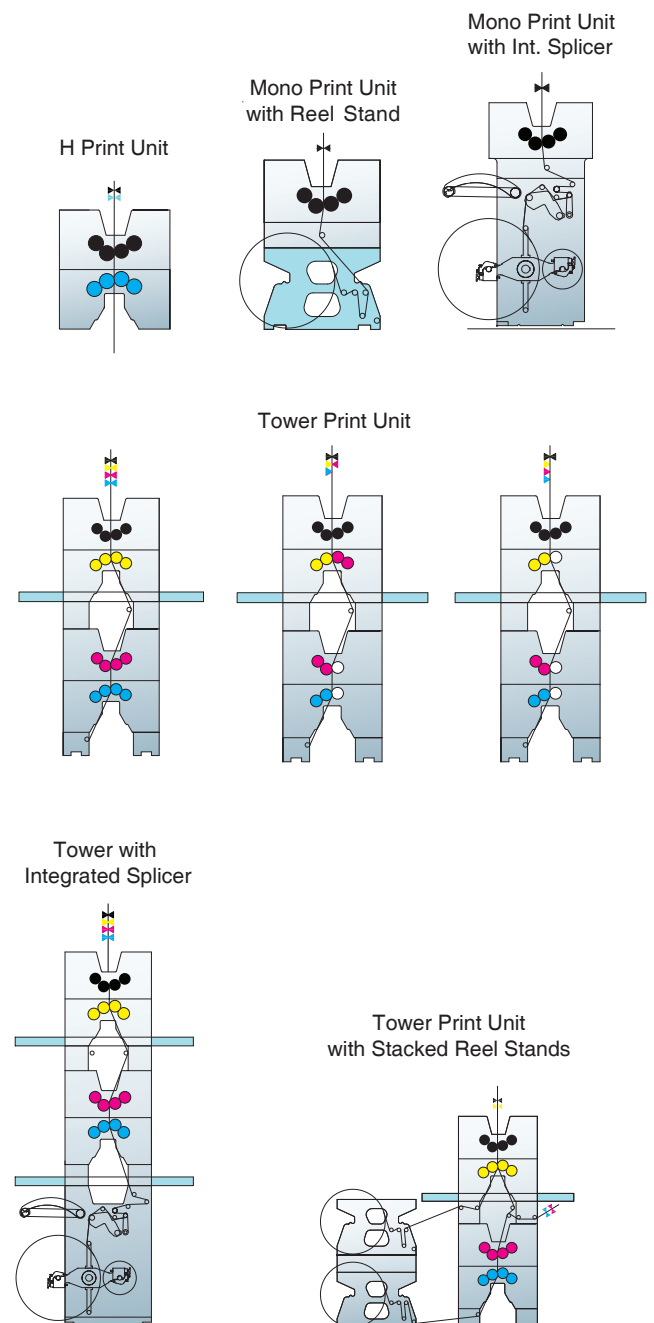

Cylinders for the Best Performance

- Solid steel, dynamically balanced hard chrome plated plate and blanket cylinders running on alloy steel bearers and supported on precision taper roller bearings.
- Toolless plate lock up.
- Register wedges for true register.
- Blanket clamping variants available.
 - Worm & Worm Wheel Blanket Clamping system.
 - Tennon Type Blanket Clamping System.
 - Narrow gap Blanket Clamping system.

T Bar blanket lock up

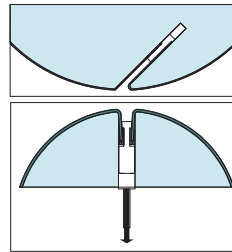

Narrow gap blanket lock up

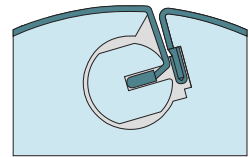

Jaw Folder - F1:2:2 / F2:2:2 / F122 BK

Features

- Jaw folder with F1:2:2 or F2:2:2.
- PIV driven RTF roller.
- Air cushioned former.
- Lap adjustment facility.
- Slitter mechanism for tabloid production.
- Folding cylinder with diameter increment facility.
- Shear pin for overload protection in the folder driveline.
- Electronic multi sheet detection facility (for 2:2:2).
- Adjustable batch counter (for F2:2:2).
- Web severer (for F2:2:2).
- Rotary Cut off compensator on Folder (Manual or Motorized).
- Quarter Fold.
- Cross perforation option for quarter fold.

F1:2:2

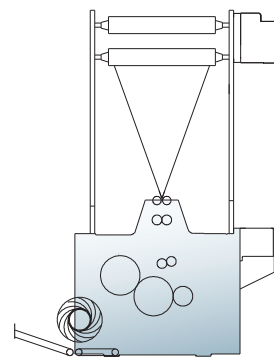

F2:2:2

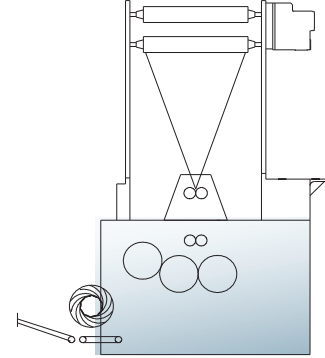

F122 BK Folder Features (for Book Printing)

- 1:2:2 Principle Jaw Folder.
- Maximum speed 35,000 IPH for 2nd Fold/QF/PF.
- Web grammage - 38 - 100 gsm, Max. 2 webs.
- Quarter Fold works on chopper principle.
- **Options Available**
- Movable former to accommodate variable web width in Quarter Fold.
- Motorized Linear cut off compensator.
- Pneumatic clutch for Overload protection and Folder drive disengage.
- 1/8 Fold.

F122BK

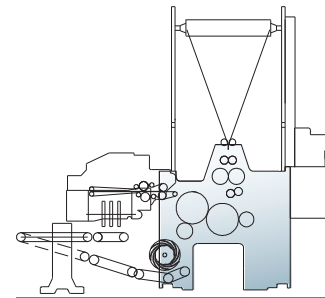

Flying Splicer (AP3550)

- Standalone Autopaster suitable for handling 1270 mm (50") reel diameter & 915 mm (36") web width.
- Splicing diameter range 700 - 1270 mm.
- Motorized belt acceleration.
- Swing type knife and sponge roller assembly.
- PLC based electro-pneumatic braking system.
- Dual braking system for consistent and precise braking.
- Reel loading and unloading from same side.
- Hydraulic web trolley moved on fixed cross rails for easy reel loading.
- Pneumatic reel shaft.

AP3550

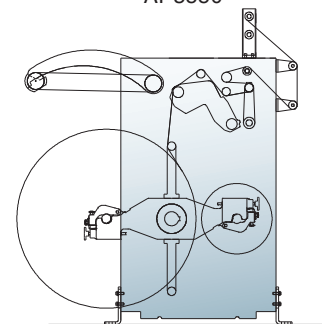

Central Console & Press Drive

- Centralised Control for Press Controls and auto sequential mode printing functions.
- Touch panel for motorized registration controls.
- Display facility for machine speed, sheet counter, batch quantity, fault indication, print unit function indication and register value.
- Manucolor remote ink zone control (optional).
- Shafted DC drive system as per configuration.
- Option of AC shafted drive.
- Option of AC Servo shaftless drive-footprint base or H base.

Central Console



Specifications

Max. Printing Speed 2nd Fold	35,000 c.p.h.	
Max. Printing Speed 3rd Fold	20,000 c.p.h. for 1:2:2 Folder (2 webs with QF) 35,000 c.p.h. for 2:2:2 Folder (4 webs with QF Chopper type)	
Max. Reel Diameter	1270 mm (50")	
Web Width	850 mm (33 1/2") - Worm & Worm Wheel Blanket Clamping System 915 mm (36") - Tennon Type Blanket Clamping System 915 mm (36") for Narrow gap Blanket Cylinder	
Printing Unit Modules	Mono, H and 4 Hi Tower with vertical web leads	
Cut-off Length	508 (20"), 533 (21"), 546 (21½"), 560 (22"), 578 (22¾"), 598.5 (23½") & 630 (24¾")	
Plate Mounting	Toolless plate lock	
Flying Splicer	Standalone, Integrated, 90°, Basement or Stacked placement	
Reel Stand	Standalone, Integrated or Stacked placement	
Jaw Folder	JF 1:2:2 upto 4 webs, JF 1:2:2 (with fix gain draw) upto 6 webs JF 2:2:2 (with fix gain draw) upto 6 webs JF 2:2:2 (with PIV Outfeed) upto 8 webs	
Data Management	PLC based	
Standard Accessories	<ul style="list-style-type: none"> • Plate punching device • Plate bending device • Set of Tools • Set of spare parts • Web trolley for loading • Centralised chilled water tank 	
Optionals	<ul style="list-style-type: none"> • Options for 1:2:2 folder <ul style="list-style-type: none"> - Quarter Fold - Chopper type - Balloon Former - Upper Balloon Former • Options for 2:2:2 folder <ul style="list-style-type: none"> - Quarter Fold - Chopper type - Double Parallel Fold - Balloon Former - Upper Balloon Former • Turner bar / Bay window • Close loop registration and cut off control system • Manucolor remote ink zone control • CIP3 interface to Manucolor for ink presetting • Spray dampening system • Shaftless Drive (footprint base or H base) • Heatset Package • OE systems integration - UV Curing, Stitcher, Gluing, VDP i.e. Bar Coding / Digital Numbering 	

CONFIGURATION

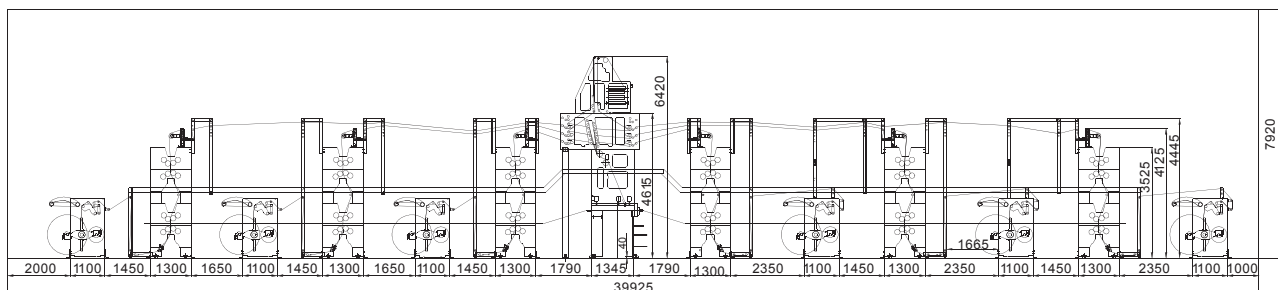

Manugraph India Ltd.,

SIDHWA HOUSE, N.A.Sawant Marg, Colaba, Mumbai.400 005, INDIA Phone : +91-22-2287 4815/4788/1191/0620,
Fax : 91-22-2287 0702, E-mail : sales@manugraph.com, Website: www.manugraph.com

Cityline Express is subject to continuous upgradation resulting from ongoing research and development and practical experiences gained. Therefore, in the interest of the customers we reserve the right to modify the specifications, features and technical data without notice. Only the specifications while confirming the order shall be binding. Cityline Express is a registered trademark of Manugraph India Ltd.